

**FOR 750 cc. V-7
AMBASSADOR ONLY**

(1st Series)

**CHANGES TO THE WORKSHOP MANUAL
FOR V-7 IN 700 cc. EXECUTION**



MOTO GUZZI



LEFT VIEW



RIGHT VIEW

FOR 750 cc. V-7 AMBASSADOR ONLY

(1st Series)

CHANGES TO THE WORKSHOP MANUAL FOR V-7 IN 700 cc. EXECUTION

SPECIFICATION CHANGES AT PAGE 5

ENGINE

Bore	83 mm (3.267")
Piston displacement	757.486 cc (46.21")
Revolutions at maximum engine speed	6500 r.p.m.
Output at maximum engine speed	55 HP SAE

Carburation

Twin Dell'Orto carburetors type SSI 29 DS (right) and SSI 29 D (left), as seen from the clutch side, provided with accelerator pump.

Lubrication

Normal lubricating pressure: 3.8 ÷ 4.2 Kgs/sq.cm. (54-60 lbs/sq.in.) controlled by relief valve.
Maximum speed: 180 Km/h (112 m.p.h.).

CHANGES AT PAGES 20 - 21 - 22

CYLINDERS - PISTONS - PISTON RINGS (see fig. 27/1 and 31/1)

Class « A »	Class « B »	Class « C »
83.000 mm. (3.2677")	83.006 mm. (3.2679")	83.012 mm. (3.2681")
83.006 mm. (3.2679")	83.012 mm. (3.2681")	83.018 mm. (3.2683")

N.B. - Cylinders must always be matched with pistons of same class.

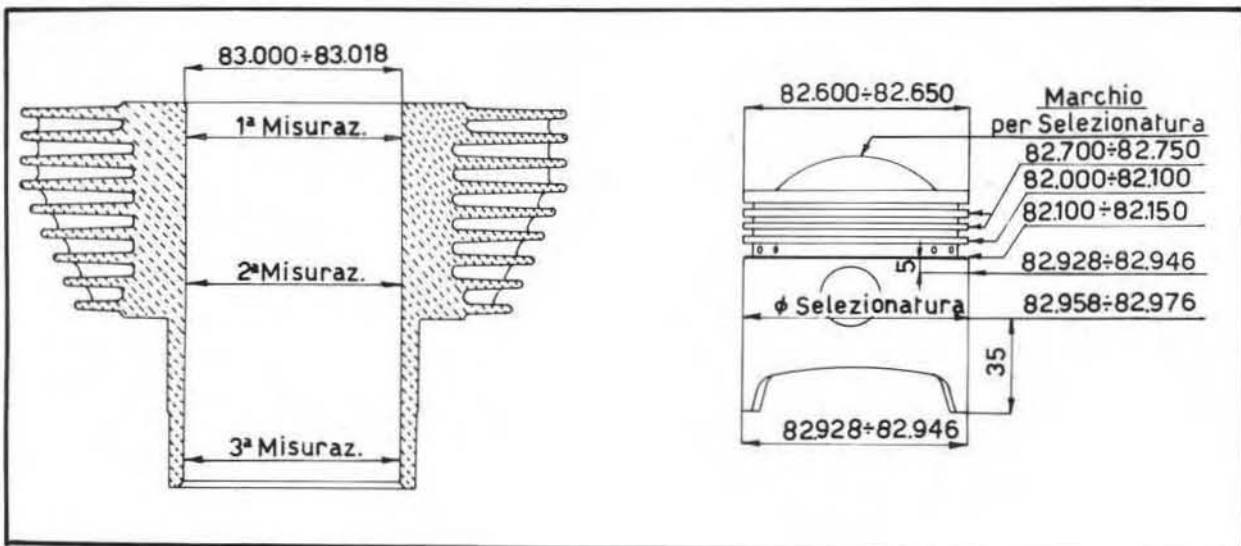

Fig. 27/1

PISTONS

Selection measurements shown in the chart must be taken at 35 mm. (1.38") from the piston bottom edge, in an orthogonal sense to the piston pin axis (see fig. 31/1).

SELECTION OF PISTON DIAMETER

Class « A »	Class « B »	Class « C »
82.958 mm. (3.2260")	82.964 mm. (3.2262")	82.970 mm. (3.2264")
82.964 mm. (3.2262")	82.970 mm. (3.2264")	82.976 mm. (3.2266")

N.B. - Pistons must always be matched with cylinders of same class.

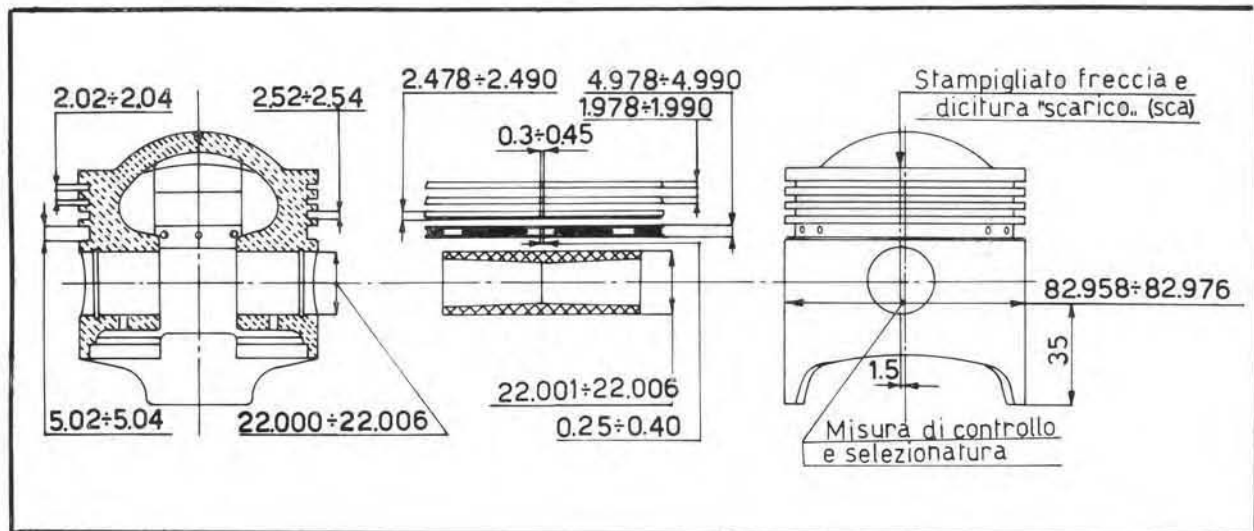

Fig. 31/1

CHANGES TO DATA PERTAINING TO CRANK MECHANISM COMPONENTS (Page 31)

Cylinder barrel dia. 83.000 ÷ 83.018 (3.2677 ÷ 3.2683")

Piston diameters:	mm.	in.
— on piston crown	82.600 ÷ 82.650	(3.2520 ÷ 3.2538")
— below top ring	82.700 ÷ 82.750	(3.2558 ÷ 3.2578")
— below second ring	82.000 ÷ 82.100	(3.2283 ÷ 3.2322")
— on the recess under the oil scraper	82.100 ÷ 82.150	(3.2322 ÷ 3.2342")
— 5 mm. (.196") under the oil scraper	82.928 ÷ 82.946	(3.2648 ÷ 3.2655")
— selection diameter 35 mm. (1.377") over the piston base	82.958 ÷ 82.976	(3.2660 ÷ 3.2667")
— at piston base	82.928 ÷ 82.946	(3.2648 ÷ 3.2655")

Piston ring grooves

Groove for top and second ring	2.02 ÷ 2.04	(0.07952 ÷ 0.08031")
3rd ring groove	2.52 ÷ 2.54	(0.09921 ÷ 0.10000")
Scraper ring groove	5.02 ÷ 5.04	(0.19763 ÷ 0.19842")

Piston rings contact width

1st and 2nd compression rings	1.978 ÷ 1.990	(0.07787 ÷ 0.07834")
3rd compression rings	2.478 ÷ 2.490	(0.09755 ÷ 0.09803")
Scraper ring	4.978 ÷ 4.990	(0.1959 ÷ 0.1963")

CARBURATION (Page 43)

This model is provided with 2 Dell'Orto carburetors type SSI 29 DS on the right and SSI 29 D on the left (as viewed from the clutch side), incorporating an accelerator pump.

Adjustment of carburetors

The accelerator pump prevents the carburation vacuums which sometime occur at sudden throttle openings. In case of any blow-back, this means the throttle valves are not properly adjusted and this will have to be attended to through screw A (fig. 69/1) and screw D (fig. 69/1) on the carburetor covers until perfect synchronization of the throttle valve opening and the idling position is obtained. This adjustment is made on a running engine and on one cylinder at the time (disconnect the plug lead of the opposite cylinder) and make sure this operation is carried out at the same engine speed on both carburetors.

Standard carburetor settings

Choke	29 mm.
Throttle slide	100
Atomizer	265
Main jet	145
Pilot jet	55
Taper needle (see C in fig. 69/1)	M 14 2nd notch from top
Floater	14 grams (1/2 oz.)
Idling screw (B in fig. 69/1)	open 1 1/2 turns

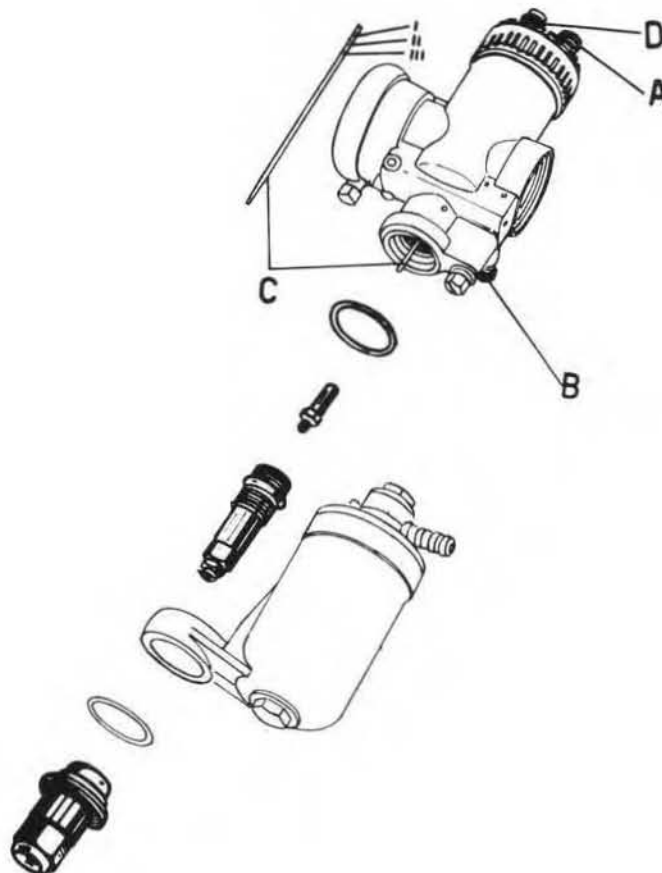

Controlling the ignition advance (fixed and automatic) on the V-7 engines using a timing light

For the purpose of checking the ignition advance, the V-7 generator pulley driven by the crankshaft has now been provided with 3 additional timing marks. When these coincide with arrow « A » which is already stamped on the timing cover, this will mean that ignition is correctly timed.

The new reference marks on the pulley can be defined as follows:

- « B » (first on the left) is the TDC position mark for the 2nd cylinder (on the left as seen astride the saddle),
- « C » is the 10° fixed advance position to the TDC,
- « D » is the 30° automatic advance position to the TDC,
- « E » is the 38° maximum advance position (fixed + automatic) to the TDC.

With the engine assembled on the machine, this control is made as follows:

- remove generator belt cover by unscrewing its 3 retaining bolts;
- connect the timing device cable to the plug of cylinder 2 (left sitting in the saddle);
- connect the 2 stroboscope cable clamps to a battery, ensuring that clamp (+) is secured to battery pole (+) and the other to pole (—).

After these connections to the spark plug and battery have been made, start the engine and direct the stroboscope light on to arrow « A » on the timing cover.

Check that this arrow is in coincidence with generator pulley marks « C », « D », « E » at the following engine speeds:

- Mark « C » at 1200 ± 100 r.p.m.
- Mark « D » at 2200 ± 100 r.p.m.
- Mark « E » at 3600 ± 100 r.p.m.

If this control shows that arrow « A » coincides with pulley marks « C », « D », « E », then the fixed and automatic advance are quite normal.

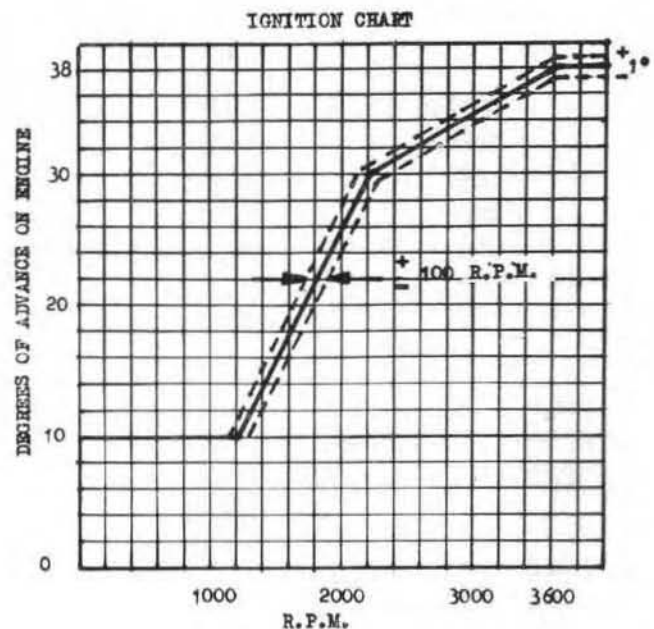
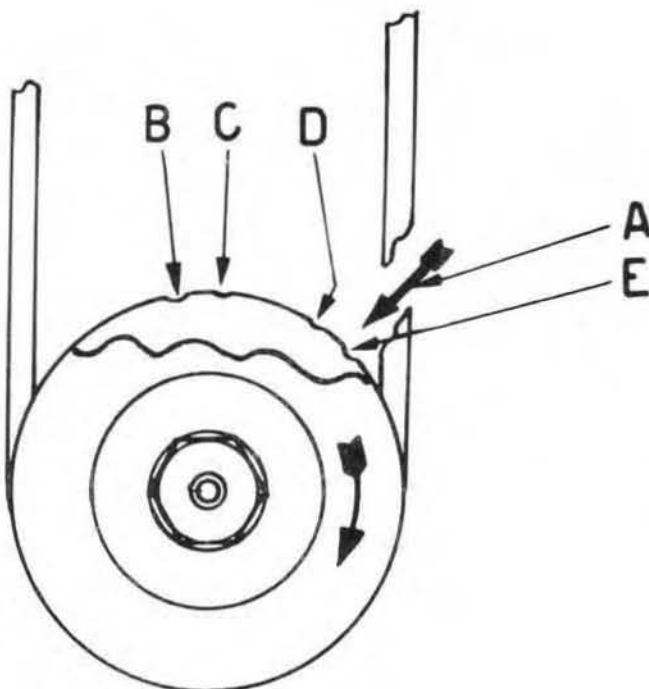

SEIMM

SOCIETÀ ESERCIZIO INDUSTRIE MOTO MECCANICHE S.p.A.
Capitale sociale sottoscritto: L. 495.000.000
Sede legale: Milano
Galleria de Cristoforis, 3 - Telefono 700965

Direzione e Stabilimenti: 22054 Mandello del Lario (Co)
Telefono: 71112 (4 linee urbane)
Telegrammi: SEIMM MANDELLOLARIO



MOTO GUZZI