

MOTO GUZZI



Quota 1100 ES

Owner's Manual

The illustrations and description in this booklet are indicative only and the manufacturer reserves itself the right to introduce any modification it may deem necessary for better performance or for constructive or commercial reasons without prior notice.

Dear rider

First of all we wish to thank you for choosing this motorcycle of our production.

By following the instructions outlined in this manual you will ensure your bike a long and troublefree life.

Before riding, please read thoroughly this manual in order to know your motorcycle's features and how to operate it safely.

All major checking and overhaul jobs are best carried out by our dealers who have the necessary facilities to quickly and competently repair your Moto Guzzi.

Repairs or adjustments by any other than a Guzzi dealer during the warranty period could invalidate the warranty right.

IMPORTANT - The text is supplemented with schematic illustrations for quick reference and better understanding of the subjects concerned.

This manual contains some special remarks:

 **Accident prevention rules for the mechanic and for the personnel working nearby.**

 **Possibility of damaging the motorcycle and/or its components.**

 **Additional information concerning the job being carried out.**

CONTENTS

CONTENTS.....	3
SPECIFICATIONS	6
Engine.....	6
Timing system	6
Feed system	6
Lubrication	6
Generator / Alternator.....	6
Ignition.....	6
Starter.....	7
Transmission.....	7
Clutch.....	7
Primary drive.....	7
Gearbox.....	7
Final drive	7
Frame	7
Suspension.....	8
Wheels	8
Tires.....	8
Brakes	8
Dimensions and weight	8
Performance.....	8
Refuelings	9
FRAME AND ENGINE NUMBERS	10
Spare Parts	10
INSTRUMENTS AND CONTROLS	11
Control panel.....	11
Light switches.....	12
Horn Button, Headlamp Flasher and direction indicators.....	13
«Choke» control.....	13
Clutch lever.....	13
Starter Button and Engine Stop Lever	14
Throttle twist grip.....	14
Brake lever, front brake	15
Brake pedal for rear brake.....	15
Gear change pedal	15
Fuel filler cap.....	15
Electric fuel cocks.....	16
Fuse box.....	16
Tool compartment	17
Helmet holder.....	17
Removing the saddle	18
Motorbike lateral supporting arm.....	18
RIDING YOUR MOTORCYCLE.....	20
Preliminary checks	20
Check:	20
Cold starting.....	20
Warm start.....	21
On the way	21

Stopping the motorcycle	21
Parking	21
RUNNING-IN	22
Breaking-in RPM	22
MAINTENANCE AND ADJUSTMENTS	23
Adjusting the clutch lever	23
Checking brake pads wear	23
Checking brake disks	23
Checking the brake fluid in the master cylinder reservoir	24
Rear brake pedal adjustment	24
Adjusting the rear shock absorbers	25
Adjusting the steering	25
WHEEL REMOVAL	27
Front wheel	27
Rear wheel	27
Max. allowed load	28
Tires	28
SERVICE SCHEDULE	29
CLEANING - STORING	30
Cleaning	30
Preparations for washing	30
Washing	30
Drying	30
Storage	30
CLEANING THE WINDSCREEN	31
LUBRICATION	32
Engine lubrication	32
Checking the oil level	32
Oil change	32
Changing the filter cartridge and cleaning the mesh filter	33
Gearbox lubrication	33
Checking the oil level	33
Oil change	33
Rear transmission box lubrication	34
Checking the oil level	34
Oil change	34
Front fork oil change	34
Greasing	35
VALVE GEAR	36
Valve clearances	36
WEBER injection-ignition system (I.A.W. 15M)	37
Description of the system	37
Fuel circuit	37
Sucked air circuit	37
Control circuit	37
Operation phases	38
Normal operation	38
Starting phase	38
Acceleration operation	38
Adjusting the idle setting and the CO	39
Fuel filter replacement	39
Changing the air filter	40
Spark plugs	40

ELECTRICAL EQUIPMENT.....	42
Battery	42
Instructions for recharging.....	42
Replacing bulbs.....	43
Headlight	43
Instrument panel	43
Tail light	43
Front and rear direction indicators	44
Bulbs.....	44
Adjusting the headlight beam.....	44
WIRING DIAGRAM.....	46
Key to wiring diagram.....	46
Fuse	46

SPECIFICATIONS

Engine

4-stroke, twin cylinder

Cylinder configuration:	90° V-twin
Bore:	92 mm
Stroke:	80 mm
Capacity:	1064 cc
Compression ratio:	9.5:1
Max. torque:	Nm 85 (kgm 8.7) at 3,800 rpm
Max. power:	Kw 51 (CV 70) a 6,400 rev/min

Timing system

With rods and rockers and 2 valves per cylinder. One camshaft in the crankcase driven by duplex chain with automatic chain tensioner.

Feed system

Indirect electronic injection, timed sequential MAGNETI MARELLI IAW 15M "Alfa-N" system, single throttlebody, Weber IW031 injectors, electric pump with pressure regulator, digital control of optimized injection times.

Lubrication

Pressure fed by gear pump.

Wire mesh and cartridge filters on oil sump.

Normal lubrication pressure 3.8÷4.2 kg/cm² (pressure valve on oil sump).

Low oil pressure sensor (electrical) on crankcase.

Generator / Alternator

On front of crankshaft.

Output power: 350W at 5000 rev./min. (14V - 25A).

Ignition

"MAGNETI MARELLI" Inductive discharge digital electronics.

Spark plugs:	NGK BPR 6 ES.
Spark plug gap:	0.7 mm
2 ignition coils	mounted on frame.

Starter

Electric starter motor 12V-1.2 Kw with electromagnetic ratchet control. Ring gear on the

flywheel. START «  » push-button on right handlebar.

Transmission

Clutch

Dry, twin driven plates. Located on engine flywheel.

Clutch lever on left handlebar.

Primary drive

With helical gears, 1:1.3529 (Z=17/23).

Gearbox

5-speed, front engaging, constant mesh.

Incorporated Cush drive

Control pedal on left side of machine.

Gear ratios:

1st 1:2 (Z=14/28)

2nd 1:1.3158 (Z=19/25)

3rd 1:1 (Z=23/23)

4th 1:0.8462 (Z=26/22)

5th 1:0.7308 (Z=26/19)

Final drive

Cardan shaft with gears

Ratio: 1:4.125 (Z=8/33)

Overall gear ratios (engine-wheel)

1st gear = 1:11.1618

2nd gear = 1: 7.3433

3rd gear = 1: 5.5809

4th gear = 1: 4.7223

5th gear = 1: 4.0783

Frame

Double steel rectangular bar with double cradle.

Suspension

Front: Marzocchi tele-hydraulic forks.

Rear: adjustable rectangular swinging arm with SACHSBOGE adjustable single shock absorber.

Wheels

Spoked, with aluminum rims.

– Front: 1.85"x21"

– Rear: 2.75"x17"

Tires

– Front: 90/90-21 54H

– Rear: 130/80-R17 65H

Brakes

Front: Two fixed disks with floating caliper with two parallel pistons. Hand lever control located on the righthand side of the handlebar.

– disk Ø 296 mm;

– braking cylinder Ø 30/32 mm;

– pump Ø 16 mm.

Rear: Disk with floating caliper with two parallel pistons.

Pedal lever control located in the centre on the righthand side of the vehicle.

– disk Ø 260 mm;

– braking cylinder Ø 28 mm;

– pump Ø 13 mm.

Dimensions and weight

Wheelbase	1.600 m
Overall length	2.260 m
Overall width	0.935 m
Height (with screen)	1.355 m
minimum height from ground	0.170 m
Weight (dry)	245 kg

Performance

Maximum speed with rider only on board and without accessories: 190 km/h. Fuel consumption: 4.9 liters for 100 km (CUNA standards).

 **N.B. - On request the motor vehicle can be equipped with a large capacity removable sidebags.**

These items do however after the aerodynamic features of the bike; it is advisable therefore not to exceed 130 kph especially when the bike is fully loaded.

Refuelings

Part	Liters	Recommended product
Fuel tank (reserve approx 4 lt.)	approx. 20	Super petrol (97 NO-RM/min.) Unleaded petrol (95 NO-RM/min.)
Oil sump	3	«Agip 4T SUPER RACING SAE 20W/50»
Gearbox	0.750	«Agip Rotra MP SAE 80W/90» oil
Rear drive (bevel set lub.)	0.250 of which 0.230 0.020	«Agip Rotra MP SAE 80W/90» oil «Agip» Rocol ASO/R or «Molykote type A»
Front forks (for leg)	0.565	Shock – Absorbers oil (SAE 7.5)
Front and rear brake circuits	--	«Agip Brake Fluid – DOT4»

FRAME AND ENGINE NUMBERS

(fig. 2)

Each vehicle is stamped with an identification number on the tubular frame, and on the crankcase.

The number stamped on the tubular frame is written in the motorcycle logbook and is the vehicle's legal identification.

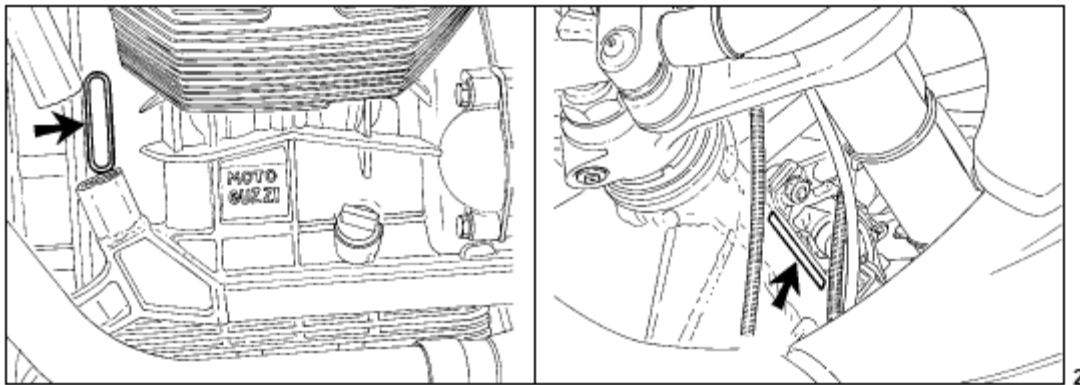

Spare Parts

Always use approved «Moto Guzzi Original Spares» only when replacing or repairing parts.

Use of spares which are not approved will invalidate warranty rights.

INSTRUMENTS AND CONTROLS

Control panel

(fig. 3)

- 1 Key switch for devices and steering lock.



Position OFF «  » vehicle stationary. Key removable (no contact).



Position ON «  » vehicle ready to be started. All circuits are on. Key not removable.



Position LOCK «  » steering locked. Engine off, no contact, key removable.

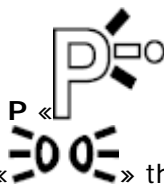

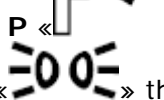
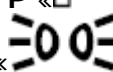
Position P «  » steering locked. Engine off; with switch «A» of fig. 4 in position «  » the parking light is on. Key removable.

In order to use the steering lock mechanism, proceed as follows:

- Turn the handlebars to the left.
- Press the key downwards and release it, then turn it in an anticlockwise

direction to the LOCK «  » or P «  » position.

⚠ WARNING: Never turn the key to position LOCK «  » or P



«  » when the engine is running.

- 2 Odometer, tachometer.
3 Partial rev counter zeroing

- 4 Rev counter.
- 5 Pilot light (green) «Neutral» for neutral position. Lights up when the gearbox is in neutral.
- 6 Pilot light (green) for flashing indicators.
- 7 Pilot light (blue) for main beam.
- 8 Oil pressure pilot light (red). Goes out when the oil pressure is sufficient to ensure engine lubrication. If the pilot light doesn't go out, then the pressure is not at the required level; in this case, stop the engine immediately and check the fault.
- 9 Pilot light (red) for generator current output. Should go out when the engine reaches a certain number of revs.
- 10 Petrol tank reserve pilot light (orange).

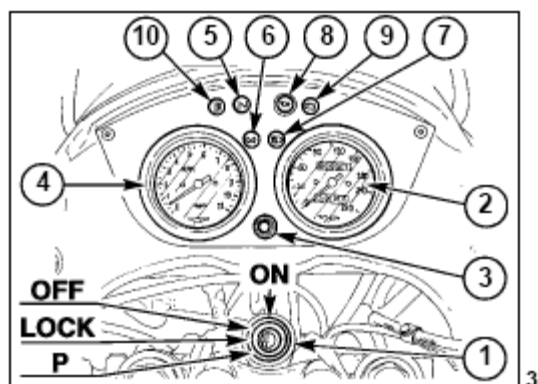

Light switches

(fig. 4)

These switches are on the left handlebar.

Switch «A»

- Position « ● » lights off.
- Position « ☹☹ » parking lights on.
- Position « ☀ » twin-filament headlamp on.

Switch «B»

With switch «A» in position « ☀ ».

- Position « ▬ ☹ » dipped beam.
- Position « ▬ ☹ » main beam.

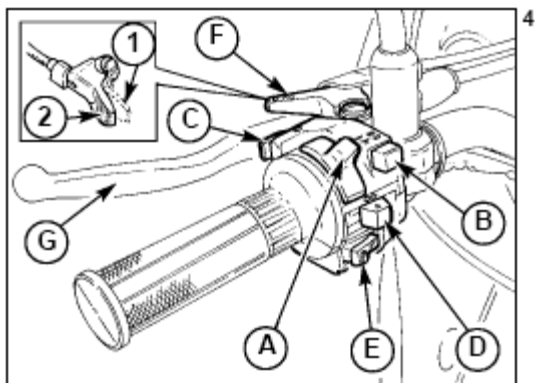

Horn Button, Headlamp Flasher and direction indicators



(fig. 4)

These are mounted on the left handlebar:

Push-button E  » sounds the electric horn when pressed.

Push-button C  » flashing light control.

Push-button «D».

- Position  » for right turn signals control.
- Position  » for left turn signals control.
- Press the switch to disconnect flashers.

«Choke» control

(«F» in fig. 4)

The «CHOKE» is on the left handlebar and is used for cold starts.

- Position «1» CHOKE on; starting position.
- Position «2» CHOKE off; engine running.

Clutch lever

(«G» in fig. 4)

This is on the left handlebar and is only to be used when starting or changing gear.

Starter Button and Engine Stop Lever

(fig. 5)

These are mounted on the right handlebar.



With the key «1» in fig. 3 in position ON «», the vehicle is ready for starting.

To start the engine:



- check that lever «B» is in position (run) «»;
- pull the clutch lever in to disengage the clutch fully;
- if the engine is cold, put the «CHOKE» control «F» in the starting position «1» (see fig. 4).



- press the starter button A «» (start).

To stop the engine in case of emergency:



- turn the lever «B» to position (off) «».



Once the engine has stopped, turn the key switch (fig. 3) in position OFF «» remove the key from the switch.

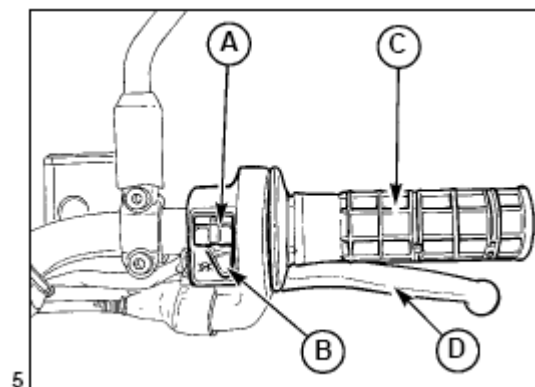

Throttle twist grip

(«C» in fig. 5)

The throttle control is on the right handlebar; turning the twist-grip towards the rider opens the throttle, turning it away from the rider closes it.

Brake lever, front brake

(«D» in fig. 5)

This is on the right handlebar and controls the master cylinder of the front brake.

Brake pedal for rear brake

(«A» in fig. 16)

This is centrally located on the right side of the vehicle and is linked to the rear brake master cylinder by a tierod.

Gear change pedal

(fig. 6)

It is located on the left of the motorcycle:

- 1st gear: push front pedal down;
- 2nd, 3rd, 4th, 5th gears: push rear pedal down;
- neutral: between 1st and 2nd gears.

● **Before changing gear disengage the clutch fully.**

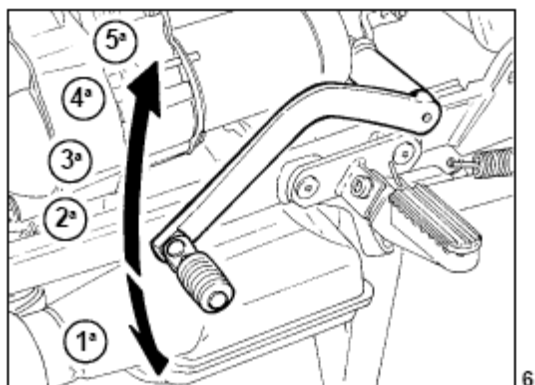

Fuel filler cap

(fig. 7)

To open, turn the key clockwise.

● **N.B. Fuel spillage caused during refueling should be cleaned immediately to prevent damage to the fuel tank paintwork.**

⚠ **WARNING:** after each refueling always check the cap for being well positioned and closed.

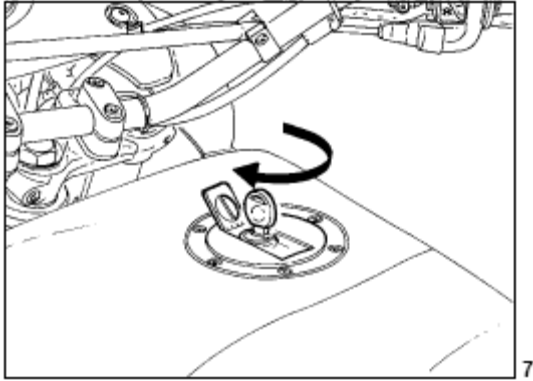

Electric fuel cocks

(Fig. 8)

The vehicle is provided with two electric cocks "A" fitted on both sides under the tank. They operate automatically, cutting off fuel flow to the throttle unit when the engine is not running.

The cocks come into play when the key of the changeover switch "1" on Fig. 3 is in its On

position «  ».

Should the cocks not be working properly, first check the condition of the fuse "3" on Fig. 9.

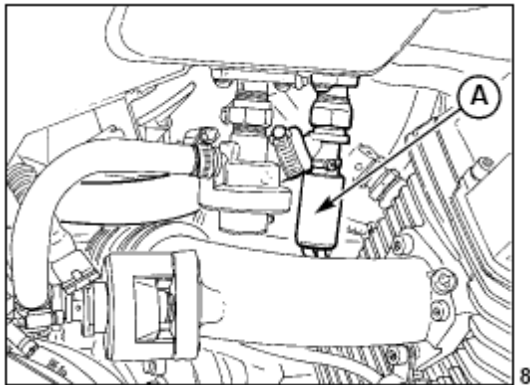

Fuse box

(fig. 9)

Situated on the rear left-hand side of the motorbike; to access it, remove the left-hand side panel.

The fuse box has 6, «15 Amp» fuses; their functions are indicated by the decal on the cover.

Before changing a burnt fuse, trace and repair the cause of the trouble.

Fuse «1»: fuel pump, coils, electric injectors.

Fuse «2»: electronic box.

Fuse «3»: electric cocks.

Fuse «4»: driving beam, traffic beam, passing light, horns, front lever stop light, rear pedal stop light, starting motor.

Fuse «5»: tail light, dashboard lights, instruments lighting.

Fuse «6»: blinkers intermittence

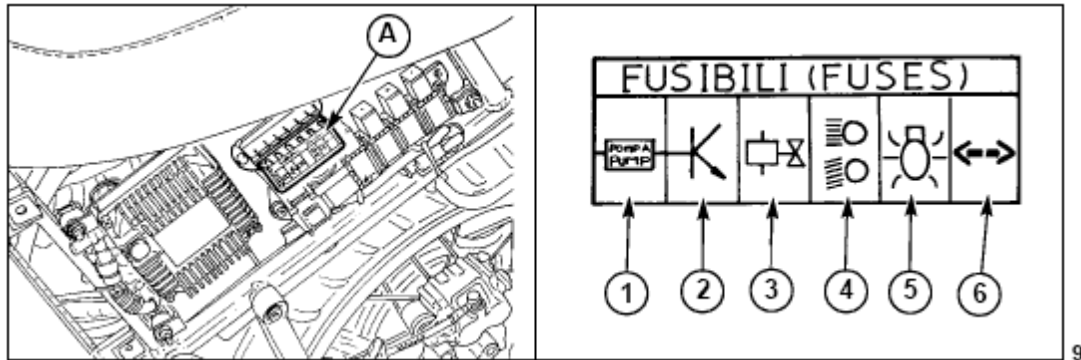

Tool compartment

(fig. 10)

To gain access to tool compartment, remove the right hand side panel.

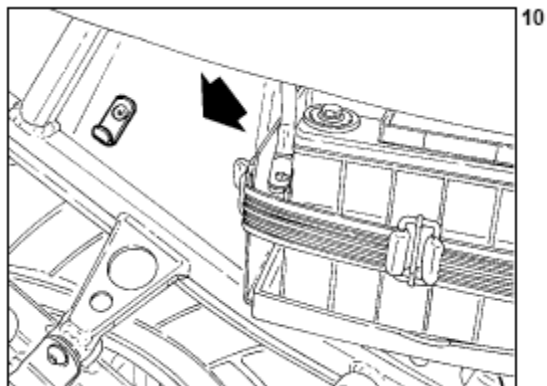

Helmet holder

(fig. 11)

The helmet can be left with the motorcycle, using the helmet holder with lock «A».

⚠ N.B. - never leave the helmet in the holder when the motorcycle is running, as it may interfere with the moving parts.

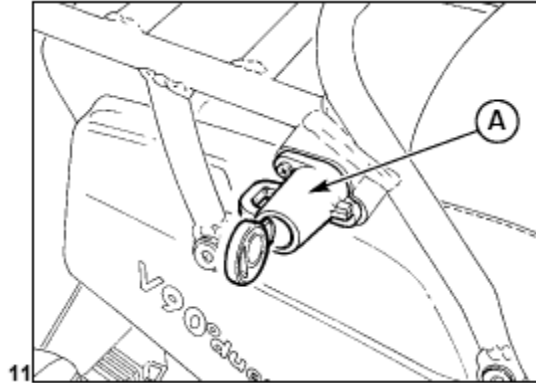

Removing the saddle

(fig. 12)

To remove the saddle from the frame, proceed as follows:

- Take off the side battery covers;
- Unscrew the saddle locking screws;
- Lift the saddle, pressing downward on the front part as shown on the figure.

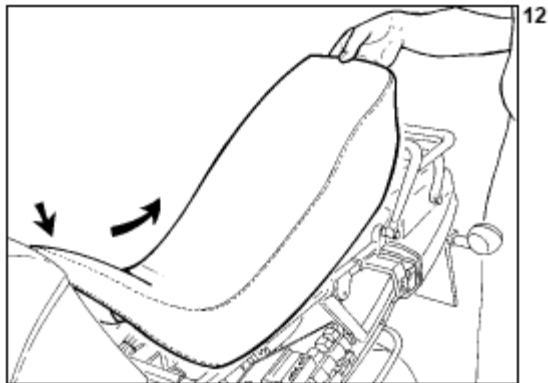

Motorbike lateral supporting arm

(«A» in fig. 13)

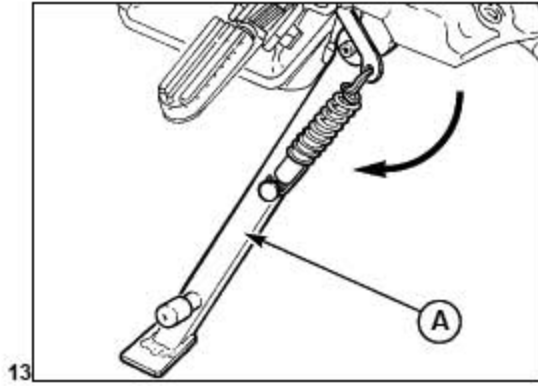

The motorbike is equipped with an arm that serves as a lateral support during parking; when the motorbike is moved to an upright position the lateral arm automatically returns to the rest position.



RIDING YOUR MOTORCYCLE

Preliminary checks

Check:



- that there is sufficient fuel in the tank;
- that the engine oil is on the right level;
- the ignition key is in position ON  » (see fig. 3);
- that the following warning lights are on:
 - **red** warning lights: oil pressure and generator;
 - **green** warning light: «NEUTRAL» indicator;
- that the «CHOKE» control lever is in the starting position (if the **engine is cold**) («1», fig. 4);
- that switch «B» (fig. 5) is in position  » (run).

Cold starting

After making the above checks, engage the clutch and press the button (A  » in fig. 5).

Once the engine has started, and before putting the «CHOKE» lever back to its normal running position («2» in fig. 4), allow the engine to idle for a few seconds in summer or a few minutes in winter.

ATTENTION! - If the «green» warning light does not come on when the ignition

 switch is on (see ON  » in fig. 3) this means that a gear is engaged; starting the vehicle in this condition could be dangerous.

Before starting, always check that the engine is in «neutral».

Warm start

Follow the same procedure as that for the cold start but without the «CHOKE» control in the start position («1», fig. 4).

WARNING! - The starter motor should not be operated for more than 5 seconds; if the engine doesn't start, wait for 10 seconds before the following



starting operation. Anyway act on the starter button A «» in fig. 5 only with the engine completely stopped.

On the way

To change gear, shut the throttle, disengage the clutch fully and engage the next gear; then engage the clutch gradually while opening the throttle.

The gear change pedal should be operated firmly and surely.

When changing down use the brakes gradually and close the throttle gradually to avoid **over-revving the engine**, when releasing the clutch lever.

Stopping the motorcycle

Close the throttle and use the brakes; just as the vehicle is about to stop disengage the clutch. These three operations should be carefully coordinated to maintain full control of the vehicle. When slowing down in normal conditions, use the gearbox to provide engine braking to slow the vehicle; take care not to **over-revving the engine**. Use the brakes (especially the front brake) with particular care when roads are slippery or wet.



To stop the engine, turn the ignition switch till the position OFF «» (see fig. 3).

Parking

On badly lit roads, leave the parking lights on.

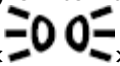

Turn the key switch to position P «» (see figure 3), and the light switch «A» in fig. 5 to position «»; and remove the key from the switch.

IMPORTANT

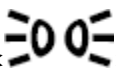

Do not leave the switch to «» for long periods or the battery will run down.

RUNNING-IN

The recommendations below should be followed when running-in:

- Before riding, run the engine at low revs until it has warmed up.
- Do not exceed the rpm shown in the table; it is also advisable to run the engine at varying speeds rather than at a constant speed.
- Before stopping reduce the speed gradually to avoid subjecting components to sudden changes in temperature.
- Remember that components need several thousand kilometers before they are properly bedded in; care taken in this period will ensure prolonged vehicle life.

After the first 500÷1,500 km

- Change the engine oil.

Should the oil level drop to the minimum level before the first 500÷1,500 kilometers have been completed then carry out a complete oil change rather than just topping up. Recommended oil: «Agip 4T SUPER RACING SAE 20W/50».

- Replace gear lubrication oil.
- Replace transmission box lubrication oil.
- Check that all nuts and bolts are tight.
- Check rocker clearance.
- Check tire pressures.

Breaking-in RPM

Kilometers	Max. RPM
From 0 to 1,000	5,000
From 1,000 to 2,000	6,000
From 2,000 to 4,000	Gradually increase rpm until maximum permissible is reached.

MAINTENANCE AND ADJUSTMENTS

Adjusting the clutch lever

(fig. 14)

There should be no more or less than 3÷4 mm of free play at the lever; turn ring nut «A» to obtain the desired play.

This adjustment can also be carried out on cable tightener «B» after having loosened lock nut «C» fitted on the right hand side of the gear box.

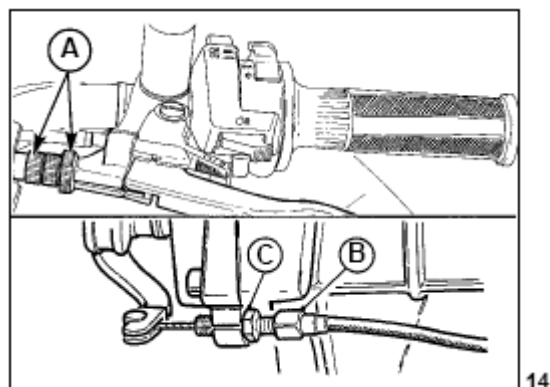

14

Checking brake pads wear

Check the thickness of the brake pads every 3000 km:

- Wear limit 1.5 mm.

If the pads are below the wear limit they should be changed.

There is no need to bleed the brakes when the new pads have just been fitted; pumping the brake lever a few times will return the caliper pistons to their normal position.

When changing the pads, also check the flexible hoses; if damaged they should be replaced immediately.



N.B. - Use the brakes with moderation for the first 100 km after fitting new brake pads, to allow the pads to get properly bedded in.

Checking brake disks

The brake disks must be perfectly clean, with no oil, grease or other dirt on them. They should also show no signs of scoring.

The torque wrench setting of the screws that fix the disk to the hubs is 3÷3.2 kgm.

Checking the brake fluid in the master cylinder reservoir

(fig. 15)

To ensure efficient operation of the brakes:

- 1 Make frequent checks of the fluid level in the front «A» and rear «B» reservoirs.
The level should always be above the minimum mark on the reservoirs.
- 2 Top up the brake fluid when necessary or at regular intervals. Only use recommended brake fluid in sealed containers for topping up.

● Fluid containers should only be unsealed immediately before they are about to be used.

- 3 The fluid in the brake reservoirs should be changed completely after about every 20,000 km, or at least once a year.

To ensure efficient braking there should be no air bubbles in the brake circuit; if the brake lever has too much travel or a spongy action, this means that there are bubbles in the brake circuit.

When flushing the Brake circuits, only use fresh brake fluid.

● Never use alcohol for flushing or compressed air for drying; we recommend the use of «trichloroethylene» for metal parts.

Never use mineral oils or greases for lubricating parts. If no suitable lubricant is available, we recommend the light greasing of the rubber and metal parts with brake fluid.

Recommended fluid «Agip Brake Fluid DOT 4».

● IMPORTANT. Fluid should be handled with care, as it may dissolve paintwork.

● These operations are best carried out by an authorized dealer.

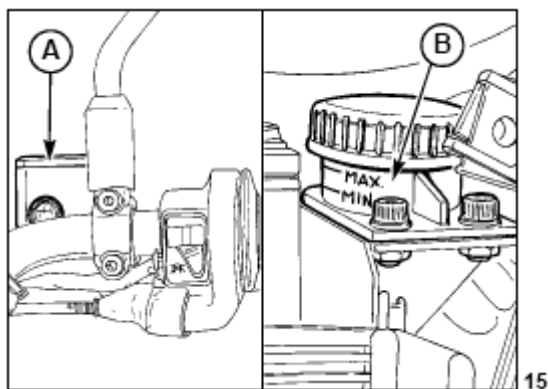

15

Rear brake pedal adjustment

(fig.16)

Check that brake pedal «A» has an idle stroke of approx. 5÷10 mm. before the end of dipstick «B» comes into contact with the brake pump master cylinder; otherwise alter the length of dipstick «B» by tightening or untightening it, after having loosened off lock nut «C». To alter the height of pedal «A» loosen off lock nut «D» and adjust screw «E», at the same time altering the length of dipstick «B» until the desired play has been achieved.

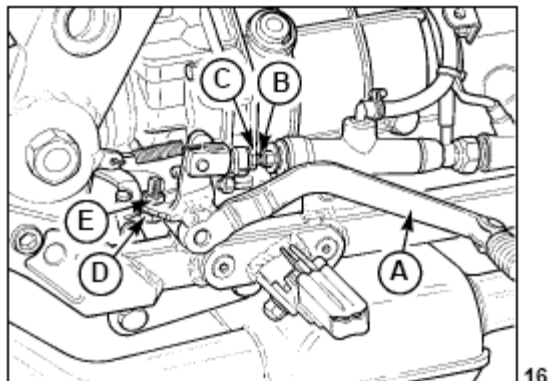

Adjusting the rear shock absorbers

(fig. 17)

The motorcycle is equipped with single shock absorbers with separate adjustment of the springs pre-loading and the action of the dampers in extension.

To adjust the pre-loading of the spring, remove the saddle using the correct wrench, loosen off ringnut «A» and adjust ringnut «B»; tightening up increases the spring pre-loading.

To adjust the hydraulic braking in extension, work on the ring nut «C». Turn it counter-clockwise to increase, clockwise to decrease.

■ **N.B.:** To avoid damaging the thread between the damper body and the ring nut «B», lubricated the thread with «SVITOL», with oil or with grease.

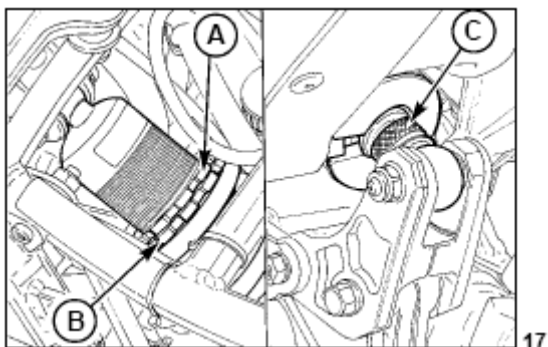

Adjusting the steering

(fig. 18)

To ensure safe riding, the steering should be adjusted to allow free movement of the handlebars without any play.

- loosen the steering head fixing bolt «A»;
- undo the steering head nut «B»;

- turn the adjuster nut «C» to take up any play.

When play has been adjusted tighten the nut «B» and the steering head fixing bolt «A».

 **It is recommended to perform the operation described above at our dealer locations.**

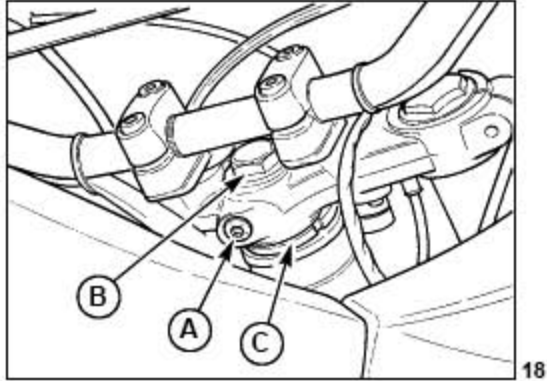

WHEEL REMOVAL

Front wheel

(fig. 19)

To remove the wheel, proceed as follows:

- place the vehicle on its center stand and keep the front wheel raised from the ground;
- undo screws «A» that secure the brake calipers to the fork, and remove the calipers «B» together with their hoses;
- undo nut «C» left hand side spindle pinch
- loosen fork spindle pinch screws «E»;
- withdraw spindle «F», noting how spacers «D» are fitted;
- remove the front wheel from the front fork legs.

When replacing the wheel, go through the instructions in reverse order, taking care of the correct position of the spacers; pump the brake lever a few times to return the caliper pistons to their normal position.

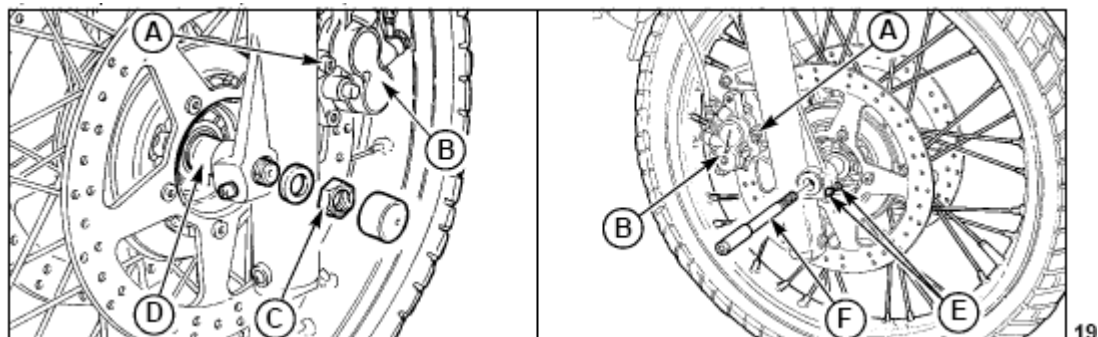

Rear wheel

(fig. 20)

To remove the rear wheel from the oscillating swing arm and final drive, proceed as follows:

- place the vehicle on the center stand;
- undo nut «A» with washer «B» from the spindle, final drive side;
- loosen spindle pinch screw «D» on swing arm;
- withdraw spindle «C» from final drive, hub and swing arm;
- remove the bracket assembly «E» after having loosened screws «F» that secure brake caliper «G» to the bracket assembly;
- tilt the vehicle to the right in order to remove the wheel from the swing arm and final drive.

To reassemble, go through the instructions in reverse order, taking care to insert the bracket assembly with caliper in the lug on the left member of the swing arm assembly.

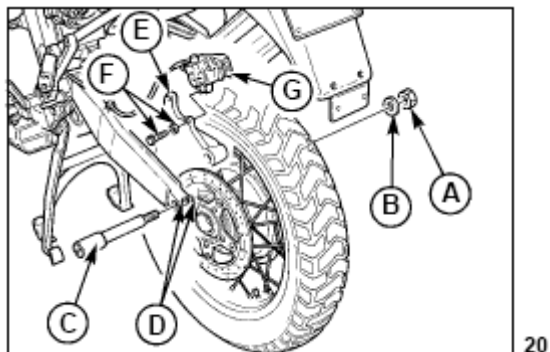

● WARNING FOR WHEELS WITH SPIKES

At each maintenance control, check for integrity and tension of the wheel spokes.

A wrong spoke tension or the breakage of one or more spokes may affect the wheel, thus compromising the vehicle safety and stability.

Always respect the maximum tolerated load specifications.

Max. allowed load

The non observance of the requirements for tires pressure or load limits can affect the handling, operation and control of the motorcycle. The max. allowed weight supported by this motorcycle is 210 kgs (passengers + luggage + accessories).

Divided up as follows:

- Front axle 65 kg.
- Rear axle 155 kg.

Tires

Tires are among those machine components which require regular checking.

Machine stability, rider comfort and safety all depend on good tire condition.

Do not use tires with less than 2 mm of tread.

Incorrect tire pressures can cause instability and excessive tire wear.

Tire pressures:

- front wheel: with one or two riders 2.3 BAR.
- rear wheel: with one rider 2.5 BAR; with two riders 2.9 BAR.

👁️ **The values indicated refer to normal use (tourism). For use at continuous maximum speed, on the motorway, it is recommended to increase the pressure in the front wheel by 0.2 BAR.**

👁️ IMPORTANT!

If a tire needs replacing, use the same make and type as the first-equipment tire. Tire pressure should be measured when tires are cold.

SERVICE SCHEDULE

MILEAGE COVERED	1,500 Km (1,000 mi.)	10,000 Km (6,000 mi.)	20,000 Km (12,000 mi.)	30,000 Km (18,000 mi.)	40,000 Km (24,000 mi.)	50,000 Km (30,000 mi.)
ITEMS						
Engine oil	R	R	R	R	R	R
Oil filter cartridge	R	R	R	R	R	R
Wire gauze oil filter	C	C	C	C	C	C
Air filter		R	R	R	R	R
Fuel filter			R		R	
Spark plugs	A	R	R	R	R	R
Rocker clearance	A	A	A	A	A	A
Carburetion	A	A	A	A	A	A
Nuts and bolts	A	A	A	A	A	A
Fuel tank, cocks filters and pipes		A		A		A
Gear box oil	R	R	R	R	R	R
Rear drive box oil	R	R	R	R	R	R
Wheel and steering bearings			A		A	
Fork legs oil	R		R		R	
Starter motor and generator			A		A	
Brake systems fluid	A	A	R	A	R	A
Brake pads	A	A	A	A	A	A

KEY: **A** = Inspections - Adjustments - Possible replacements - Servicing. / **C** = Cleanings. / **R** = Replacements.

Occasionally, lubricate joints and cables; every 500 km (300 miles) check the engine oil level.

In any case, replace the motor oil, the oil filter and the brake fluid, oil at least once a year.

Periodically check the tension of the wheel spokes.

CLEANING - STORING

Cleaning

Preparations for washing

Before washing the vehicle, the following parts should be covered with a waterproof material: the rear part of the silencers, the clutch and brake levers and pedals, the throttle twist-grip, the left-hand light switch, the ignition key switch, the shaft with driving couplings.

Washing

Avoid spraying water too much pressure on the instruments and the front and rear hubs.

Drying

Remove the protective coverings.

Thoroughly dry the vehicle.

Test the brakes before using the vehicle.

■ N.B. - To clean the painted parts of the engine unit (engine, gearbox, transmission box, etc.) the following products may be used: diesel oil, petrol or water-based neutral detergents for car cleaning.

These products should be washed off immediately with water; do not use water at high temperatures or pressures.

Storage

If the vehicle is to remain idle for a considerable period of time (e.g. for the winter period) it should be stored in the following way:

- clean the vehicle thoroughly;
- empty the fuel tank and feeding system. If left for a long time, the fuel will evaporate leaving incrustation and residue;
- remove the spark plugs and put a few drops of SAE 30 oil into each cylinder. Turn the crankshaft for a few revolutions and then replace the spark plugs;
- reduce the tire pressures by 20%;
- position the vehicle so that its wheels are not touching the ground;
- smear a layer of oil on unpainted parts to prevent rust;
- remove the battery and store in a dry place away from the direct sunlight and where there is not danger of frost; check the battery charge once a month;
- cover the vehicle but in such a way that the air can circulate.

CLEANING THE WINDSCREEN

The windscreen can be cleaned using most of the soaps, cleaners, waxes and polishes commercially available for glass and plastic.

The following precautions should be taken:

- **do not wash or polish the windscreen in direct or strong sunlight or when temperatures are high;**
- under no circumstances use solvents, lyes or similar products;
- do not use abrasive substances, pumice, sand/emery paper, files, etc.;
- wash all dust and dirt away before polishing. Small superficial scratches can be removed using a mild polish;
- paint or sealing compound can be removed before harden by using diesel, isopropyl alcohol or butyl cellosolvent (do not use methyl alcohol);
- use soft cloths, sponges, chamy leathers or cotton wool; do not rub too hard. Do not use paper towels or man-made fiber cloths as they tend to scratch the windscreen.

Deep scratches cannot be removed by hard rubbing or the use of solvents.

LUBRICATION

Engine lubrication

Checking the oil level

(fig. 21)

Check the crankcase oil level every 500 km; the oil should reach the «Max» mark on the dipstick «A». If the oil is below this level, top up with the recommended type and grade of oil.

N.B. - The oil level check should be carried out after the engine has run for a few minutes: the dipstick plug «A» should be screwed fully home.

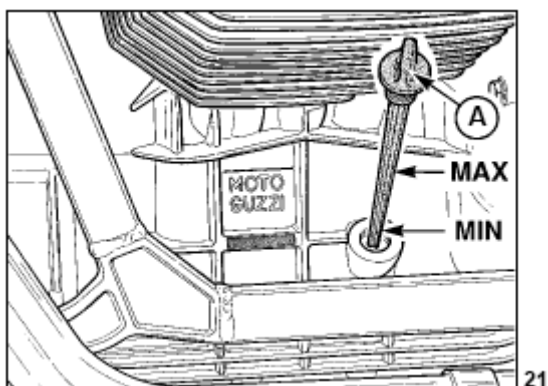

Oil change

The oil should be changed after the first 500÷1,500 km and then every 10,000 km. change the oil when the **engine is warm**.

Allow the sump to drain fully before filling up with new oil.

«A» Oil filler plug with dipstick (fig. 21).

«B» Oil drain plug (fig. 22).

Oil required: 3 liters of «Agip 4T SUPER RACING SAE 20W/50».

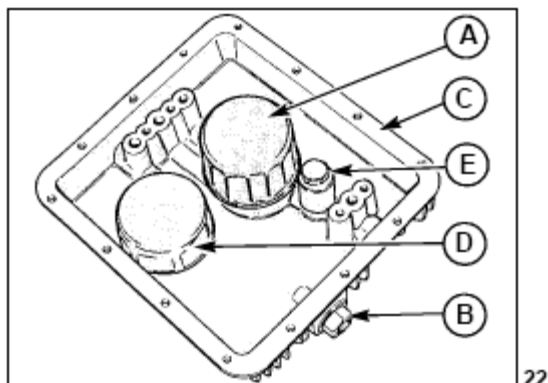

Changing the filter cartridge and cleaning the mesh filter

(fig. 22)

After the first 500÷1,500 km (first oil change) and afterward every 10,000 km, replace the filtering cartridge «A» by doing the following:

- unscrew the drain plug «B» and allow the sump oil to drain off fully;
- undo the screws and remove the sump cover «C» from the crankcase: this assembly includes the filter cartridge «A», the mesh filter «D» and the oil pressure valve «E».
- When changing the filter cartridge «A» it is also a good idea to remove the mesh filter «D» and wash it in petrol; dry by blowing with compressed air. Blow the oil ducts in the sump out with compressed air and refit the mesh filter.

Do not forget to fit a new sump gasket when refitting the sump.

 **It is recommended to perform the operation described above at our dealer locations.**

Gearbox lubrication

(fig. 23)

Checking the oil level

Every 5,000 km check that the oil just reaches the level at plug hole «B».

If the oil is below the level, top up with the recommended grade and type of oil.

Oil change

The gearbox oil should be changed after the first 500 to 1,500 km, and later on every 10,000 km. Drain the oil when the gearbox is warm as the oil is more fluid and drains more easily.

Remember to allow the gearbox to drain fully before filling with new oil.

«A» Filler plug.

«B» Level plug.

«C» Drain plug.

Quantity required: 0.750 liters of «Agip Rotra MP SAE 80 W/90» oil.

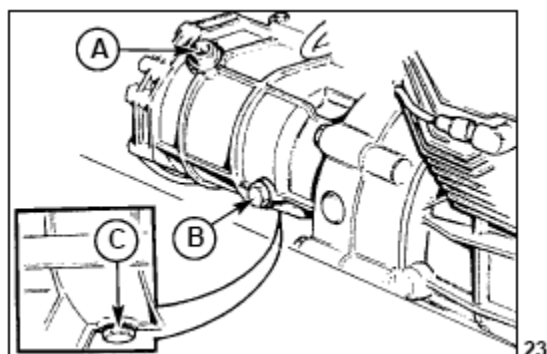

23

Rear transmission box lubrication

(fig. 24)

Checking the oil level

Check the oil level every 5,000 km; the oil should just reach the level plug hole «A»; if the oil is below the level top up with the recommended grade and type of oil.

The oil level check will have to be carried out by means of the fork in the horizontal position.

Oil change

The transmission oil should be changed after the first 500 to 1,500 km, and later on every 10,000 km. Drain the oil when the gearbox is warm as the oil is more fluid and drains more easily.

Remember to allow the gearbox to drain fully before filling with new oil.

«A» Level plug.

«B» Filler plug.

«C» Drain plug.

Quantity required: 0.250 liters of which:

0.230 liters of «Agip Rotra MP SAE 80 W/90» oil.

0.020 liters of «Agip Rocol ASO/R» oil or «Molykote type A» oil.

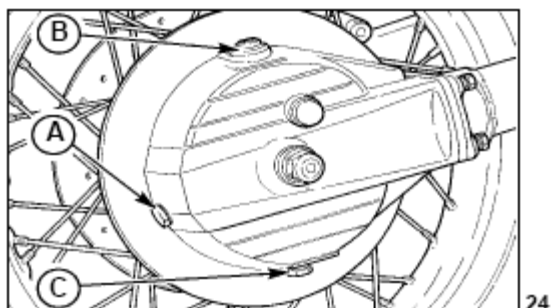

24

Front fork oil change

(fig. 25)

After the first 500÷1,500 Km and afterwards every 20,000 km or at least once a year.

About 0.565 liters of oil is needed for the «MARZOCCHI (SAE 7.5)» shock absorbers.

To change the fluid in the front forks, proceed as follows:

- with the vehicle on the center stand, loosen the side bolt «C» that attaches the steering head to the fork;
- unscrew the upper hexagonal-head plug «B»; then remove the drain plug «A»;
- refit the plug «A» and put the required quantity of oil;
- refit the plug «B» and retighten the side bolt. Repeat the same procedure for the other side.

 These operations are best carried out by an authorized dealer.

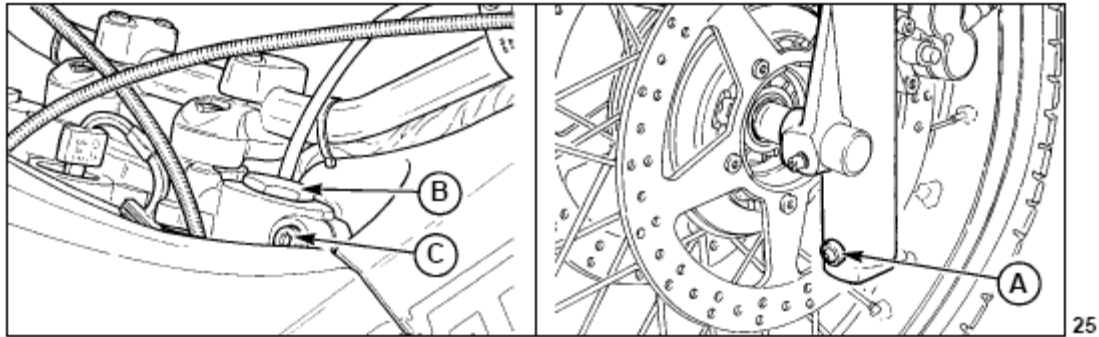

Greasing

To grease:

- steering bearings;
- swinging arm bearings;
- control rod joints;
- side stand fittings;

Use: «Agip Grease 30».

VALVE GEAR

Valve clearances

(fig. 26)

The clearance between rocker arms and valves should be checked and adjusted after the first 500÷1,500 km and every 5,000 thereafter or if the valve gear becomes excessively noisy.

Adjustment should be carried out with the engine cold and the piston at TDC in the compressions phase (valves closed).

Remove the rocker box cover and proceed as follows:

- 1 loosen nut «A».
- 2 turn the adjuster screw «B» to obtain the clearances:
 - intake valve 0.10 mm;
 - exhaust valve 0.15 mm.

Use a suitable feeler gauge «C» to measure the clearances.

Remember that if the clearances are greater than those specified, valve gear will be noisy; if the valves don't close fully this can cause problems such as:

- loss of compression;
- engine overheating;
- valve burn-out, etc.

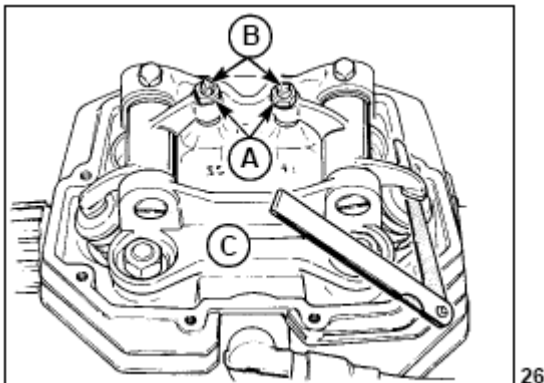

WEBER injection- ignition system (I.A.W. 15M)

In the Weber injection-ignition system type "alfa/N" the engine speed and the throttle position are used to measure the quantity of sucked air; when the quantity of air is known, measure the fuel quantity in relation with the desired strength. Other sensors in the system allow to adjust the main operation, on particular condition. Moreover, the engine speed and the throttle angle allow to calculate the optimal ignition advance on every operation condition. The quantity of air sucked from each cylinder per cycle, depends on the air density in the suction manifold, on the single displacement and on the volume efficiency. The volume efficiency is experimentally calculated on the whole operation field of the motor (rpm and engine load) and is stored in the electronic unit. The control of the injectors, each cylinder, is "time sequenced", i.e. the two injectors are controlled on the basis of the suction sequence, while the delivery can already begin, for each cylinder, from the expansion phase until the suction phase, already begun. The timing for the initial delivery is contained in the electronic unit.

Static inductive-discharge ignition with dwell control provided by the power module (in-built in the electronic box) and ignition advance mapping stored in the electronic box. The coils receive the control inputs from the I.A.W. 15M unit (that calculates the ignition advance) via the power modules.

Description of the system

Fuel circuit

The fuel is injected along the suction pipe of every cylinder, in the upper side of the suction valve.

It includes: tank, pump, filter, pressure adjuster, electroinjectors.

Sucked air circuit

The circuit includes: air filter, suction pipe, floated casing.

Downstream the throttle valve is installed the plug for the pressure adjuster.

The potentiometer for the throttle position is assembled on the throttle shaft.

The max pressure sensor (built into the unit) and the air temperature sensor are installed upstream from the throttle valve.

Control circuit

With this circuit, the electronic unit detects the engine conditions and the performance of the fuel exhaust and the ignition advance.

It includes: battery, ignition switch, two relays, electronic unit with built-in max pressure sensor, ignition unit, air temperature sensor, throttle position potentiometer, two injectors, oil temperature sensor, injection timing/RPM sensor.

Operation phases

Normal operation

When the engine is in standard thermic conditions, the 15M I.A.W. unit calculates the phase, the injection time, the ignition advance, only by interpolation on the corresponding stored presettings, according to rpm and throttle position.

The resulting amount of fuel is delivered to the two cylinders with two subsequent injections.

The count of the initial delivery moment, for each cylinder, is made by means of a presetting that depends on the number of revolutions.

Starting phase

When the ignition switch is in operation, the 15M I.A.W. unit feeds the fuel pump for few time and detects the throttle angle and the temperature of the engine.

After starting the engine, the unit receives the revolution and phase signals, which allow it to control the injection and the ignition.

To make the starting phase easy, an enrichment of the main quantity, upon the oil temperature, is performed.

After the starting phase, the unit begins the check of the advance.

Acceleration operation

During acceleration, the system increases the delivered fuel quantity, in order to obtain the best way of guide.

This condition is detected when the throttle angle variation reaches appreciable values, the enrichment factor is determined upon the oil and air temperatures.

WARNING!

In order not to cause damages to the electronic ignition system, follow the precautions hereunder:

- **in case of battery removal or refitting, be sure that the ignition switch is in**



position OFF « »;

- **do not disconnect the battery with engine on;**
- **be sure of the perfect efficiency of earth cables of electronic boxes;**
- **do not electric weld on the vehicle;**
- **do not use other electric devices for starting;**

- to avoid either malfunctioning or inefficiencies of the ignition system, the spark plug wire connections (spark plug cap) and the spark plugs must be of the recommended type (as original equipment);
- do not make any plug current check if the original spark plug cap are not fitted otherwise the electronic power box would be irreparably damaged;
- in case of assembling of antitheft devices or other electric devices, absolutely do not touch the electric ignition/injection system.

In the electronic injection/ignition system is not possible to adjust the carburetor setting (air/gasoline ratio).

● IMPORTANT!

Do not adjust the mechanical and electronic components in the electronic injection/ignition system.

- Any adjustment or maintenance work should be carried out at the dealer's workshop.

Adjusting the idle setting and the CO

(fig. 27)

- To set the idling speed to 1,200 rpm, adjust screw «A».
- Open and close the throttle a few times to check that the idling remains constant.
- The CO value should be between 1%÷2%.

● N.B. - The idle setting should be adjusted when the engine is at running temperature.

These operations are best carried out by an authorized dealer.

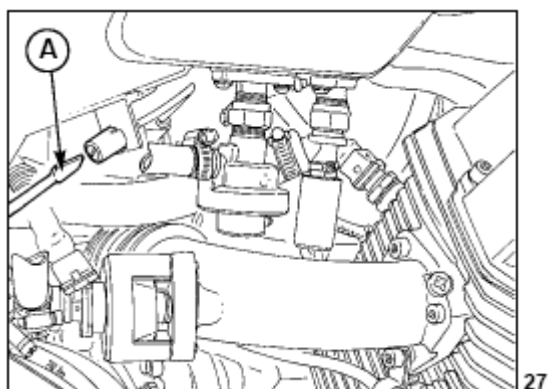

Fuel filter replacement

(«A», fig. 28)

The filter is provided with a filtering element made of paper, with 1,200 cm² surface, and 10 μm; filtering power: it is necessary due to the high sensibility of injectors to foreign elements.

The filter is assembled under the saddle between the pump and the pressure adjuster and on the external cover there is an arrow showing the direction of the fuel.

Every 20,000 km it is necessary to replace it.

 To change the fuel filter, it is advised to use an authorized dealer.

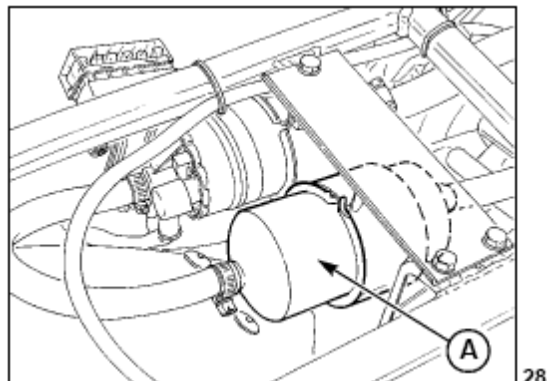

Changing the air filter

(«A» of fig. 29)

Check the air filter every 5,000 km and clean by blowing with compressed air; change every 10,000 km.

This filter is mounted in a special case above the motor group, the saddle and fuel tank must be removed in order to have access to it.

 For the above operations it is advisable to apply to a Moto-Guzzi dealer.

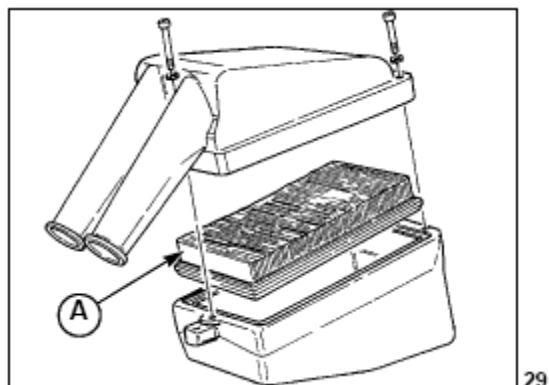

Spark plugs

(fig. 30)

Use the following types of spark plug:

- NGK BPR 6 ES

Spark plug gap: 0.7 mm.

Remove the spark plugs for cleaning and checking at the intervals.

Refit the plugs by hand taking care not to cross thread them, they should screw home easily; it is then recommended to tighten them manually for some turns and to use the provided suitable key, in order to lock them when the **engine is cold**.

Even if used plugs appear to be in good condition, they should be replaced every 10.000 km.

● **N.B. - Values lower than 0.7 mm can compromise the engine life.**

● **WARNING!**

To avoid either malfunctioning or inefficiencies of the ignition system, the spark plug wire connections (spark plug cap) and the spark plugs must be of the recommended type (as original equipment). Do not make any plug current check if the original spark plug cap are not fitted otherwise the electronic power box would be irreparably damaged. Bear in mind that this also applies to any vehicles equipped with the electronic ignition systems listed below.

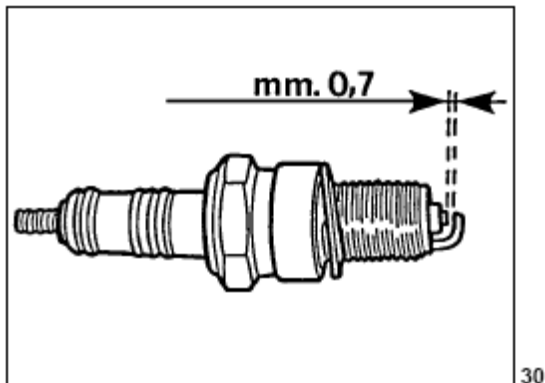

ELECTRICAL EQUIPMENT

The electrical equipment consists of the following:

- Battery.
- Starter motor with electro-magnetic ratchet.
- Generator-alternator fitted to the front of the crankshaft.
- Fuel reserve signal device.
- Light switch.
- Ignition coil.
- Electronic control unit (I.A.W. 15 M).
- Phase and revolution sensor.
- Blinker unit
- Voltage regulator.
- Fuse box (no. 6, 15 A fuses).
- Electronic control unit.
- Pump control microswitch, coils, electro-injectors.
- Starter microswitch.
- Headlight.
- Tall light.
- Direction indicators.
- Selector indicators.
- Light direction indicator, horn and headlamp flasher switch.
- Hazard warning lights, switch.
- Starter and stop device.
- Electric horns - Horn switch.

Battery

The battery has a voltage of 12 V and a capacity of 13 Ah; it is charged by the generator. To reach the battery, remove the right-hand side panel. This is a hermetic (maintenance free) battery that does not require any electrolyte level control or topping up.

Instructions for recharging

To recharge the battery, use a constant voltage charger set to 14.7 ÷ 15V at 25°C.

 **WARNING**

- Contains toxic materials (Pb and H₂SO₄)
- Extremely high current, avoid short circuit.
- DO NOT charge in a gas tight container.
- Sealed Lead Battery.

Must be recycled or disposed of properly.

 These operations are best carried out by an authorized dealer.

Replacing bulbs

Headlight

(fig. 31)

To change the bulbs, loosen the screws "A" to remove the instrument panel, disconnect the wiring connections from the rear, remove the rubber protective cap and release the lamps.

After having reassembled the unit, make sure no other wiring connection has been accidentally disconnected.

The lamp holder, complete with side light bulb, is push fitted.

 **N.B. - When changing the headlight bulb (driving/dipped beams) take care not to touch the glass part of the bulb with your fingers.**

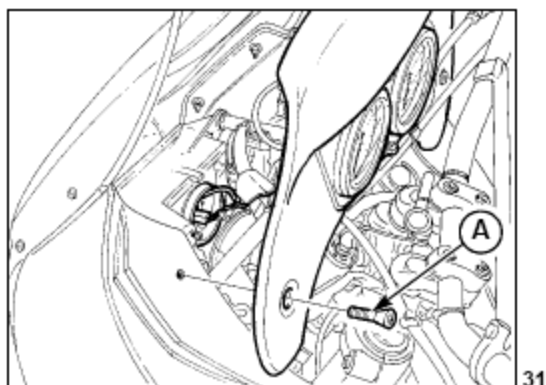

Instrument panel

(fig. 31)

Remove the instrument panel, after having loosened screws «A», remove the control warning lamp units and instrument lamp units, and change the bulbs.

Tail light

(fig. 32)

Undo screws «A», which attach the reflector to the unit; to remove the bulb from its holder, press in and turn.

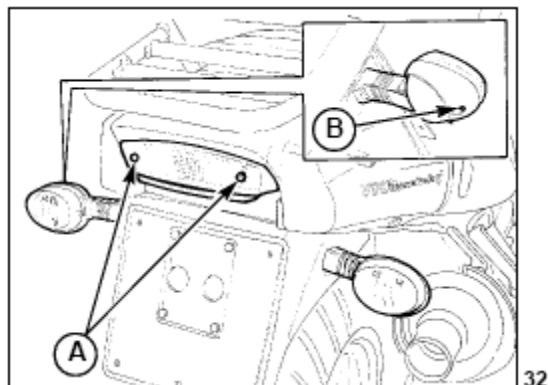

Front and rear direction indicators

(fig. 32)

Undo screws «B» that hold the reflectors to the direction indicator units to remove it ; To remove the bulb from its holder, press in and turn.

■ N.B. - Do not overtighten the reflector retaining screws as this will break the reflector.

Bulbs

Headlight:

- Driving beam 55 W
- Dipped beam 55 W
- Side/parking lights 5 W

Tail light:

- Number plate, stop light 5/21 W

Direction indicators 10 W

Speedo, rev counter lights 3 W

Instrument panel warning lights 1.2 W

Adjusting the headlight beam

(fig. 33)

The headlight beam should always be kept adjusted at the correct height to ensure good visibility and to avoid dazzling on coming traffic.

To adjust the vertical orientation of the beam, work on the adjustment screw «A» after having removed the instrument panel. Turn the screw clockwise to raise the beam, counter-clockwise to lower it.

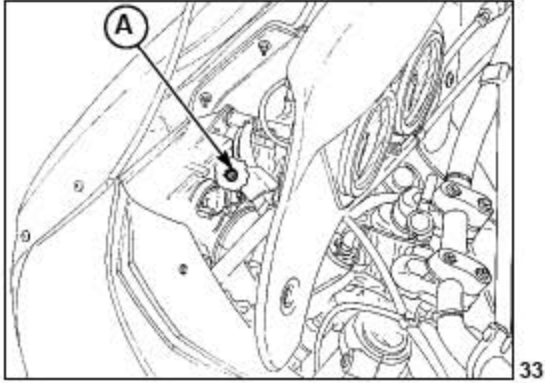

WIRING DIAGRAM

Key to wiring diagram

- | | |
|---|---|
| 1 Driving beam 55W (H3 halogen) | 30 5-way AMP connector |
| 2 Tail light 5W | 31 R.H. Device (Ignition - Run) |
| 3 Dipped beam 55W(H1 halogen) | 32 Front brake stop switch |
| 4 Front R.H. direction indicator, 10W | 33 4-way AMP connector |
| 5 Front L.H. direction indicator, 10W | 34 Key ignition switch |
| 6 Dashboard | 35 IAW 15M electronic unit |
| 7 1-way AMP connector (RPM sensor, dashboard side) | 36 Air temperature sensor (NTC ATS05) |
| 8 PAKARD 10-way connector (dashboard) | 37 Three-way diagnosis AMP connector |
| 9 Oil pressure switch | 38 Warning light LED |
| 10 Neutral position switch | 39 Cylinder ignition coil AT, LH (BAE850AK) |
| 11 Fuel level switch | 40 Cylinder ignition coil AT, RH (BAE850AK) |
| 12 Horns | 41 Power relay for injection (MINIRELAY SIEMENS) |
| 13 Horn relays (MINIRELAY SIEMENS) | 42 Safety diode |
| 14 PAKARD 10-way connector (L.H. device) | 43 ECU electronic unit relay (MINIRELAY SIEMENS) |
| 15 L.H. control device: lights, direction indicators, horn | 44 Fuel pump |
| 16 Intermittence | 45 L.H. injector (IW031) |
| 17 Alternator 12 V330 W | 46 R.H. injector (IW031) |
| 18 Voltage regulator | 47 Phase sensor (SEN813) |
| 19 Start relay (MINIRELAY SIEMENS) | 48 Motor oil temperature sensor (NTC WTS05) |
| 20 Starter | 49 Throttle potentiometer (PF10) |
| 21 Battery 12V 13Ah | 50 Max. pressure sensor inside the electronic unit ECU |
| 22 Rear brake stop switch | 51 1-way AMP connector (key closed supply) |
| 23 L.H. rear direction indicator 10W | 52 1-way AMP connector (RPM sensor, injection side) |
| 24 Rear stop light 21W | |
| 25 Rear tail light 5W | |
| 26 R.H. rear direction indicator 10W | |
| 27 Fuse box (see table) | |
| 28 Solenoid valves (electric taps) | |
| 29 Light relays (MINIRELAY SIEMENS) | |

Fuse

- F1** Pump, coils, injectors 15A
- F2** ECU electronic unit 15A
- F3** Electric taps 15A
- F4** Driving, dipping beam, horn, start, stop light 15A
- F5** Tail lights 15A
- F6** Direction indicators 15A

Arancio	=	Orange
Azzurro	=	Light blue
Bianco	=	White
Giallo	=	Yellow
Grigio	=	Grey
Marrone	=	Brown
Nero	=	Black
Rosa	=	Pink
Rosso	=	Red
Verde	=	Green
Viola	=	Violet
Bianco-Azzurro	=	White-Light blue
Bianco-Giallo	=	White-Yellow
Bianco-Marrone	=	White-Brown
Bianco-Nero	=	White-Black
Blu-Nero	=	Blue-Black
Giallo-Nero	=	Yellow-Black
Nero-Grigio	=	Black-Grey
Rosso-Bianco	=	Red-White
Rosso-Blu	=	Red-Blue
Rosso-Giallo	=	Red-Yellow
Rosso-Nero	=	Red-Black
Rosso-Verde	=	Red-Green
Verde-Grigio	=	Green-Grey
Verde-Nero	=	Green-Black
Rosa-Nero	=	Pink-Black
Marrone-Nero	=	Brown-Black
Bianco-Blu	=	White-Blue
Bianco-Verde	=	White-Green

